

E-60 Series Master Wire Harness Connection Example Guide

DATACLUTCH®

CALL (716) 652-0625

2 AMP FUSE MUST BE CONNECTED AS SHOWN
IF NOT THE WARRANTY IS VOID

INPUT CHANNELS HAVE MULTIFUNCTION USE
SENSOR TYPES & SIGNAL CONNECTIONS MAY VARY ON YOUR SYSTEM
OTHER OPTIONS AVAILABLE NOW
DATACLUTCH INSTALL SHEETS ARE ALSO AVAILABLE

- (a) DEDICATED 3 WIRE ANALOG EXPANSION PORT
- (b) USE 18 OR 20 GA WIRE ON USED CONNECTOR PINS
- (c) 2 WIRE SENSOR CABLE PART # EC2W-XXX (XXX= SPECIFY LENGTH REQUIRED IN INCHES)
- (d) 3 WIRE EXTENDER CABLE PART # EC3W-XXX (XXX= SPECIFY LENGTH REQUIRED IN INCHES)
- (e) 3 DIGITAL AND 1 ANALOG OR DIGITAL SIGNALS
- (f) 1 DIGITAL AND 5 ANALOG OR DIGITAL SIGNALS
- (g) LED LIGHT ON WIRE HARNESS

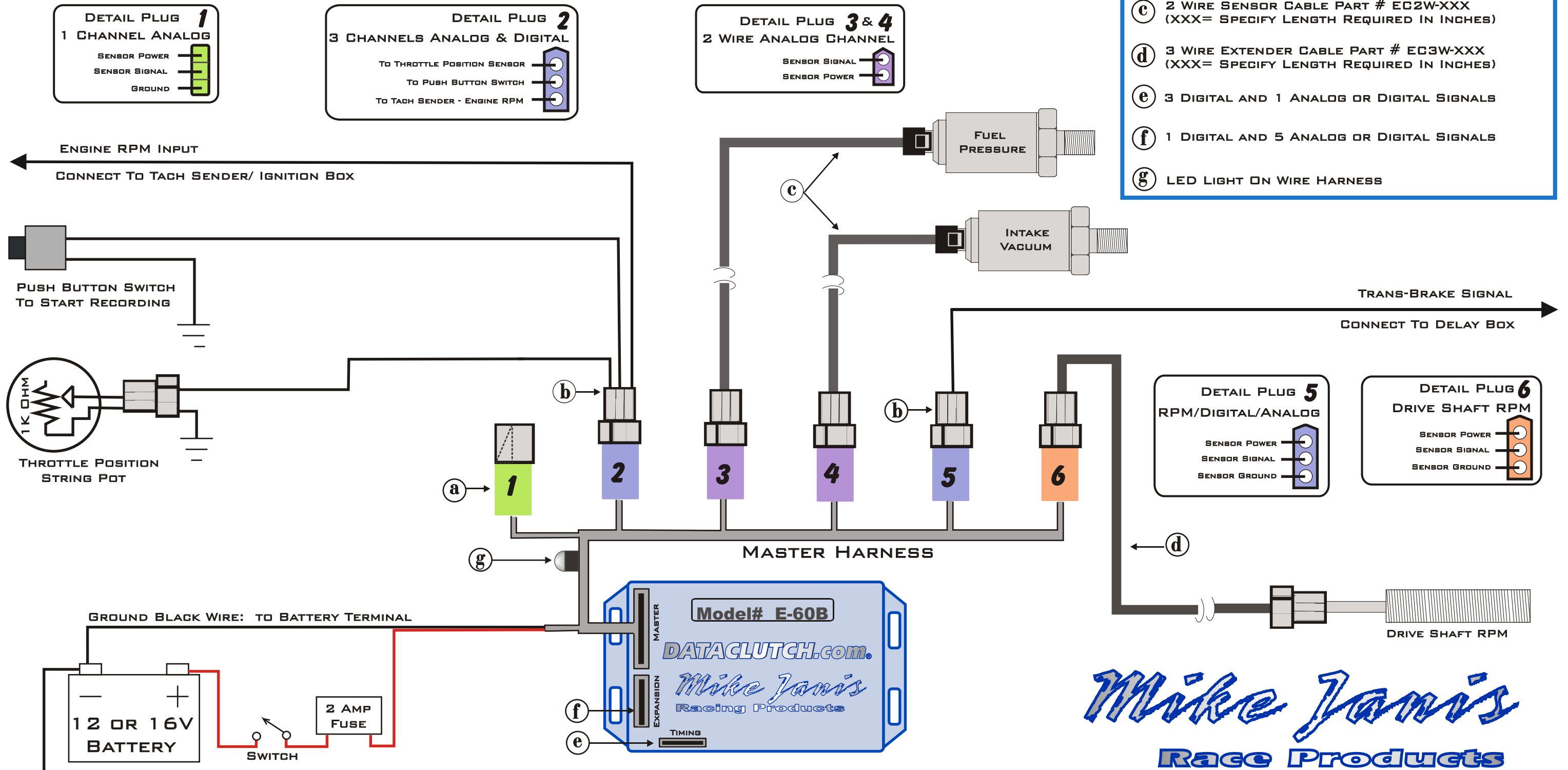

Mike Janis
Race Products

DATACLUTCH® DATA ACQUISITION RECORDERS